



# Decisive Features



## X Continuous quality control

- 100 %
- for more safety
- day and night - round the clock

## X Diagnostic functions with real concrete support

- when occurs the error
- where occurs the error
- what to do about it

## X Ok or not ok - results in just a fraction of a second

## X Classify and sort parts

## X Total retraceability

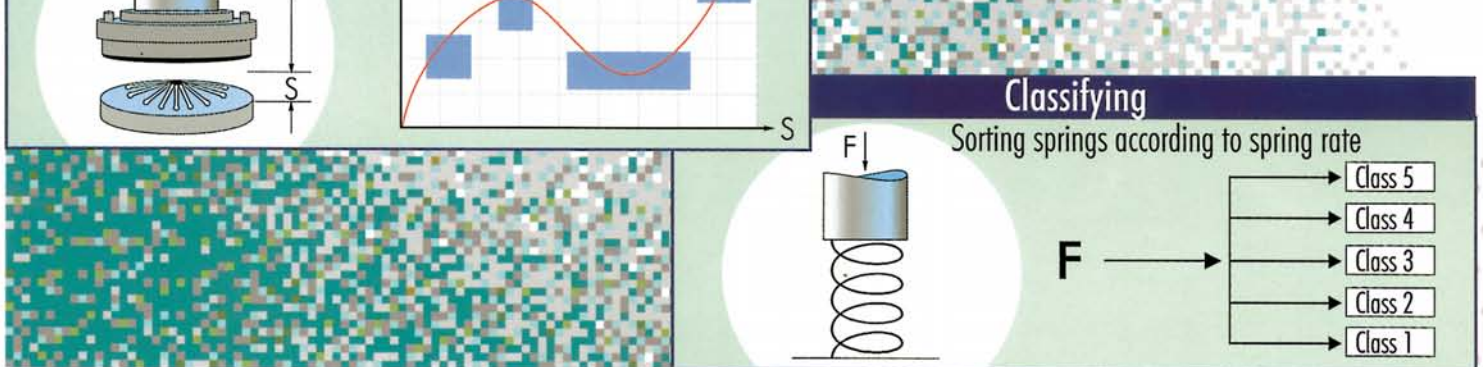
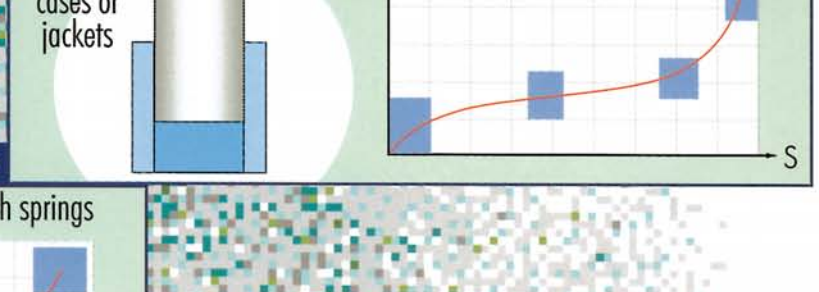
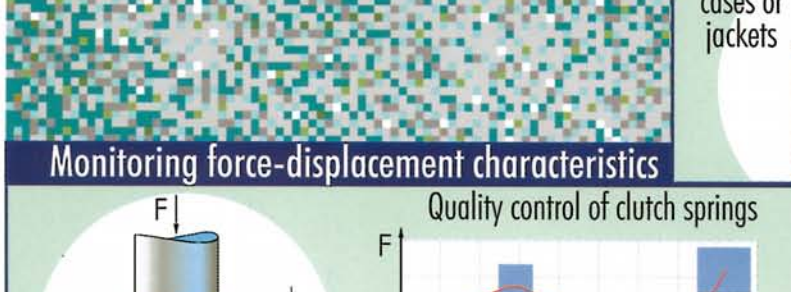
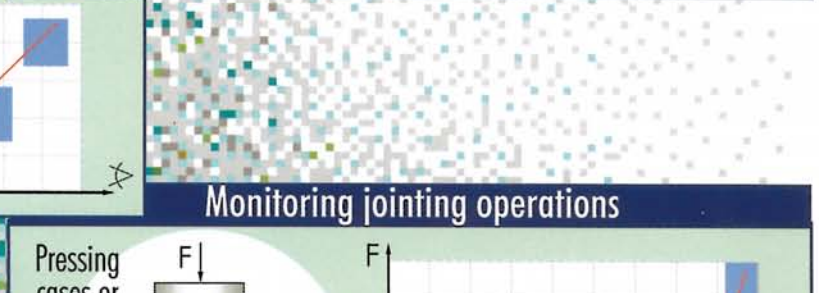
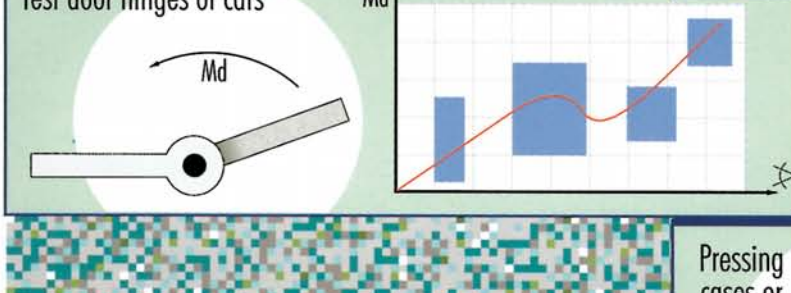
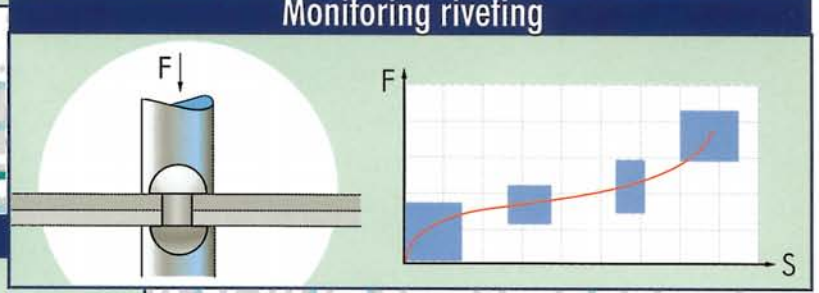
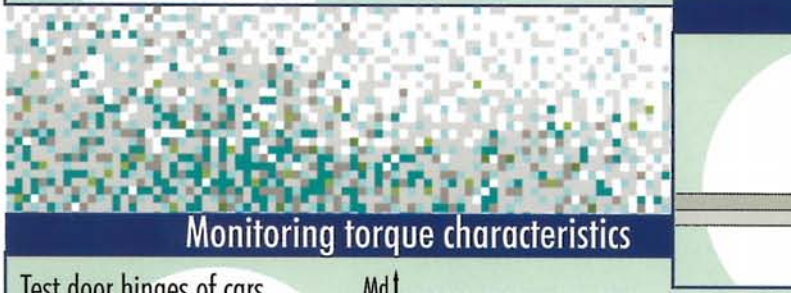
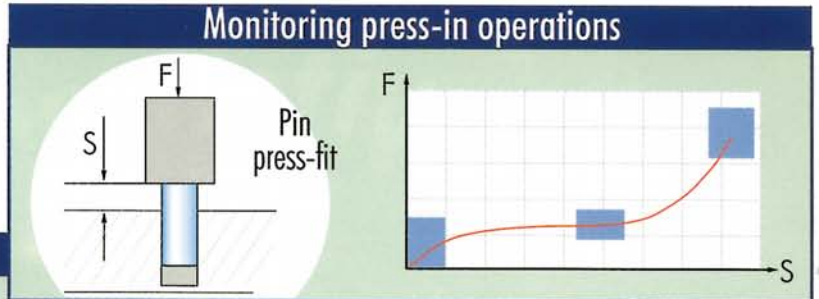
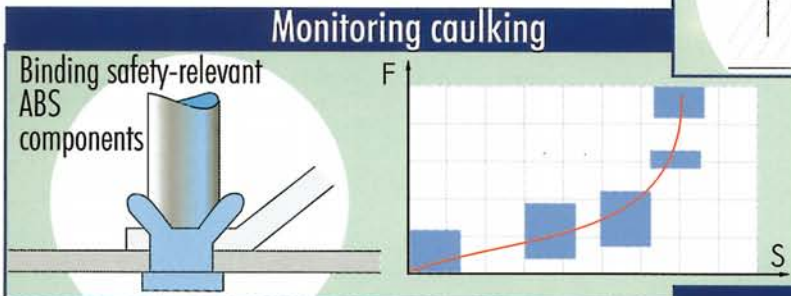

## Press-Fit Control with DIGIFORCE® 9306

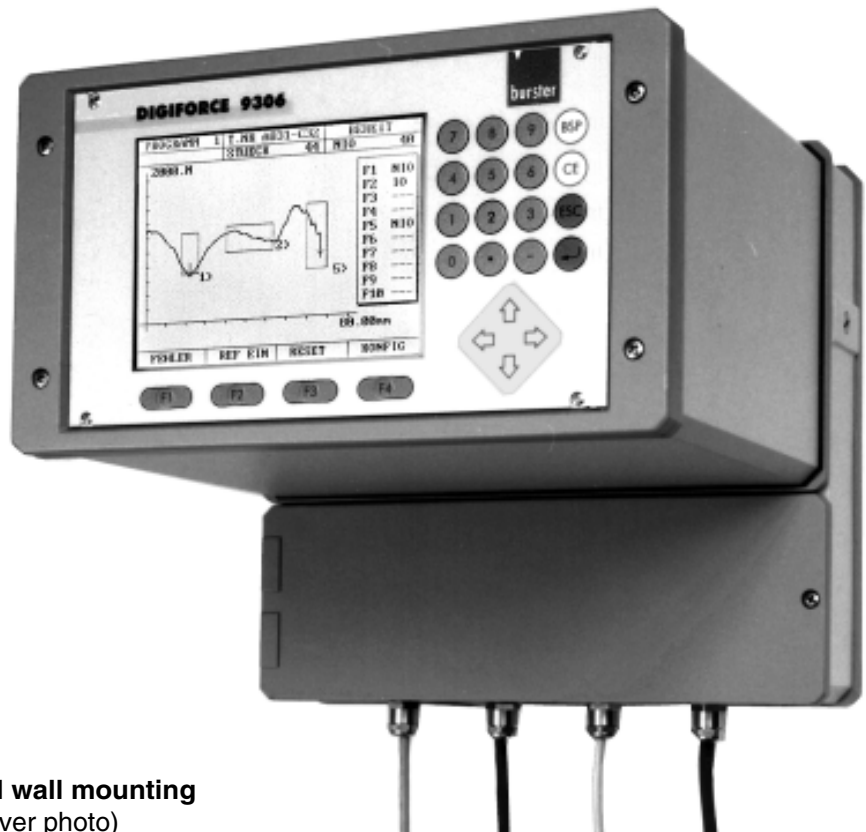

**NEW !  
Profibus  
connection**

Shortest access times  
using additional  
interface processor  
and Dual Ported  
RAM data  
architecture  
(see  
page 6)

**IP-65 version for vertical wall mounting**  
(Desk/rack version, see cover photo)

- ✓ **Controls operations involving pressing, fastening, rotating and panning, such as force and displacement, torque and angle, etc.**
- ✓ **Windows check threading, curve characteristics, hysteresis, slope, block degree and block force**
- ✓ **Controls up to 10 workpieces per second**
- ✓ **32 different types of workpieces in 32 measuring programs**
- ✓ **Instrument software and operation manuals available in English, French, German, Italian, Portuguese and Spanish**
- ✓ **Fast measuring program switching through PLC**
- ✓ **Provides extensive data about process status**
- ✓ **Built-in statistical functions**
- ✓ **Large contrast-rich display for curves and diagnostics**
- ✓ **All standard sensors connectable, all on board**
- ✓ **All sensor interfaces on board**
- ✓ **No more hardware calibration required, everything is menu-controlled**
- ✓ **Access authorization using various USER codes**

**Application**

DIGIFORCE® controls processes in which precisely defined functional relationships between two measurement variables must be demonstrated. For example such relationships exist between force and displacement during pressing, and between torque and angle of rotation during bolting. DIGIFORCE® is used widely in the monitoring of fastening, riveting, and caulking operations, as well as in torque control in production of hinges, seatback adjustment mechanisms, rotary switches, etc. DIGIFORCE® is universally applicable. It is used first of all in the design and development phase for determining the setpoint characteristics of yet undetermined curves. DIGIFORCE® computes and displays these curves graphically. Such a curve can be stored at any time and be re-used as a reference curve.

In a later phase, DIGIFORCE® is integrated in the production environment and fulfills its primary monitoring function in full synchronization with the production system. In addition to being used in fully automated production lines, DIGIFORCE® can also be found assisting many manual tasks such as acceptance sampling in shipping and receiving. Quick workpiece changes are no problem for DIGIFORCE®. Up to 32 workpiece specific parameter sets are available, which can either be controlled by PLC or by menu. The highly comprehensive diagnostics screens provide the user with constant data on the production process. Trend curves allow the user to tell when and how a process is running away. Basic help menus are available to assist in problem solving.

**Block Diagram**

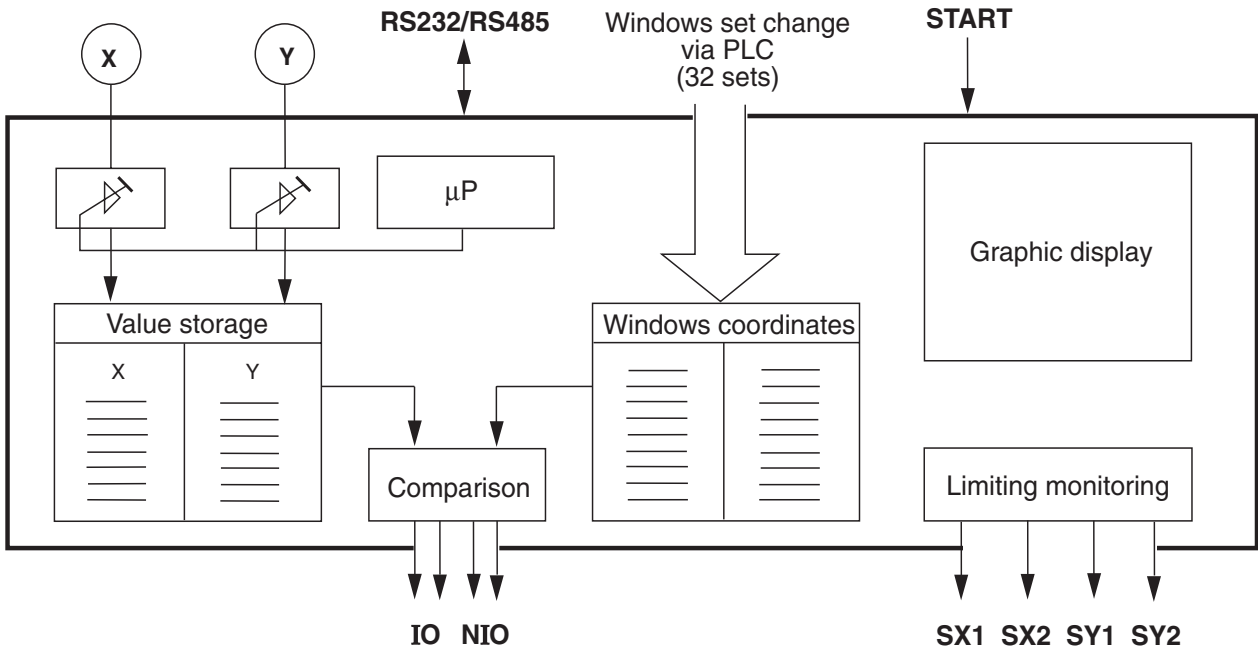

**Testing Procedure**

After initiating START on the device, the sensors measure the X-Y-coordinates in form of a curve, write them to memory, display them as a graph, and evaluate them by means of a special windows technology. If a curve measurement passes through the windows as defined, DIGIFORCE® returns a GOOD (OK), otherwise a BAD (NOK) signal. For universal evaluation of various types of curves, DIGIFORCE® offers 5 different types of windows. A total of 10 different windows of various types can be allocated to each curve measurement.

The windows can read and evaluate positive (from left to right) and negative (from right to left) curve directions. In the example opposite, windows 1 through 4 are positive and 5 through 7 are negative. The windows only evaluate the curve for the direction that has been assigned to them, regardless of whether the curve also runs through the same window in the other direction (as in the case of window 4).

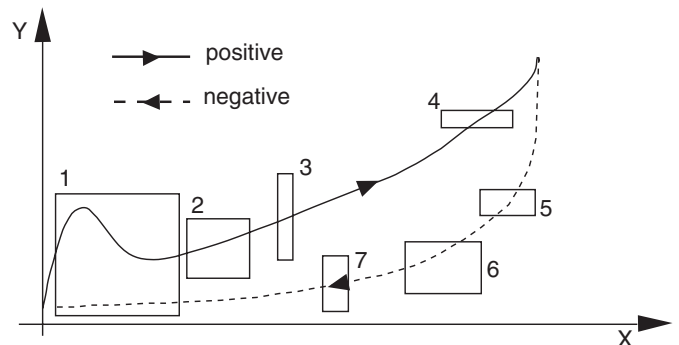

Figure 2: Windows set with positive and negative windows

## Testing Criteria and Window Types

### Pass-through Window

This type of window checks the characteristics of the curve within the range of the window. The curve has to pass through the defined ingress and egress sides of the window without violating any of the other window boundaries. The entry and exit side can be specified (left, right, up, down).

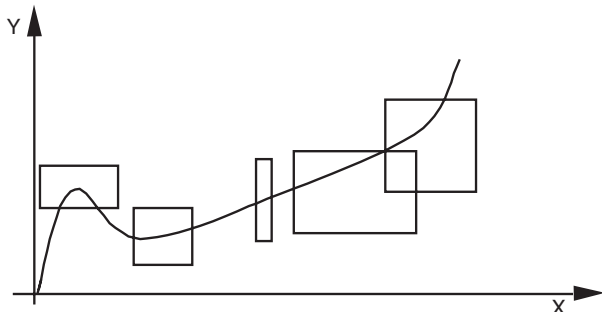

Figure 3: Using pass-through windows

### Hysteresis Window

This type of window evaluates a progressive or retrograde curve of Y-values for a random point on the X-axis. These hysteresis are used, for example, as quality characteristics in hinged elements, switches, etc.

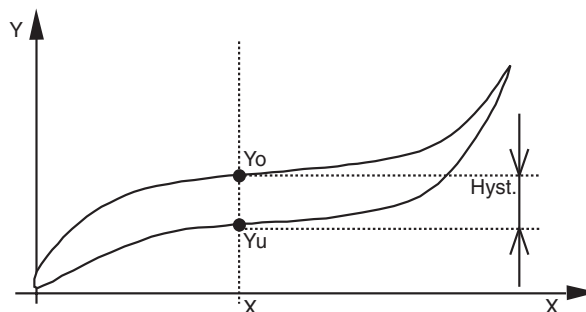

Figure 6: Using hysteresis windows

### Threading Control Window

This type of window is specially designed for pressing and fastening routines. It checks whether the fastened parts have been threaded properly and have not jammed. A real-time signal indicates this event and can be used, for example, to activate the upward stroke of the press.

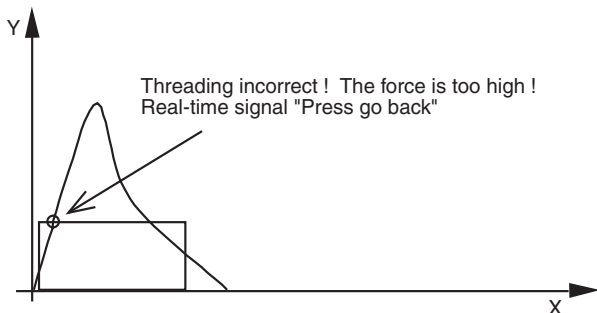

Figure 4: Threading control window

### Gradient Window

Checks the slope of a curve section between two X-values. The slope is defined from

$$\text{degree} = (Y_{x2} - Y_{x1}) / (X2 - X1).$$

A maximum of 10 gradient windows can be allocated per window set.

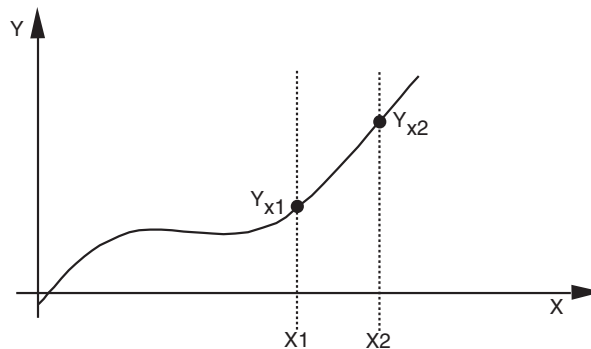

Figure 7: Gradient Window

### Block Window

The block window monitors the block dimension and the block force of a pressing operation, for example. For this type of window, the curve must enter the pre-determined side of entry and must not exit the window.

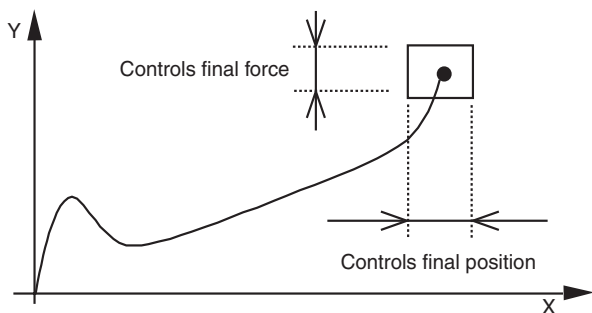
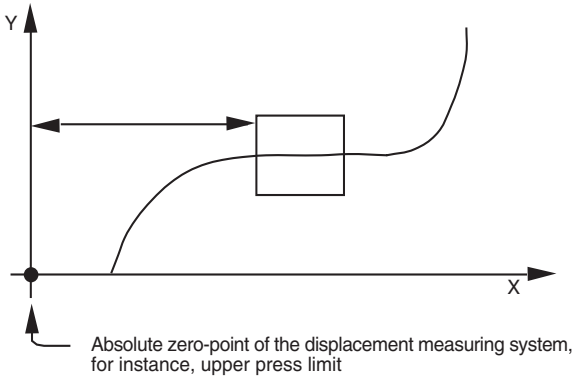

Figure 5: Using the block window

**Reference points for the evaluation windows**

The DIGIFORCE® offers 4 different reference points:

**ABSOLUTE REFERENCE**



**TRIGGER REFERENCE**

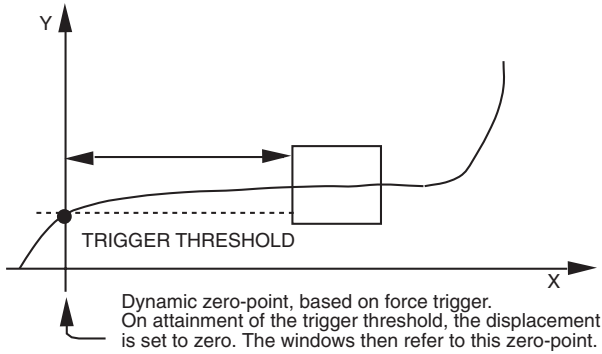

**FINAL FORCE REFERENCE**

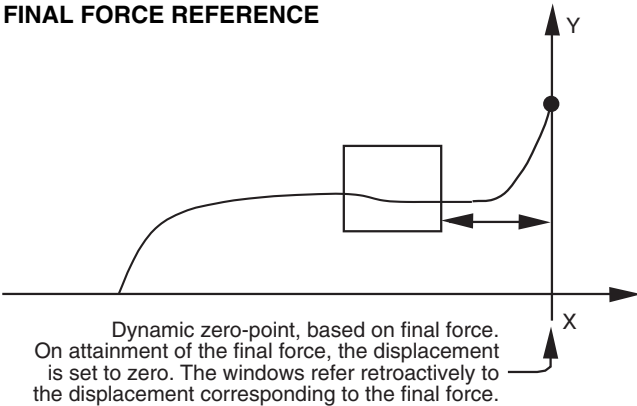

**BLOCK WINDOW REFERENCE**

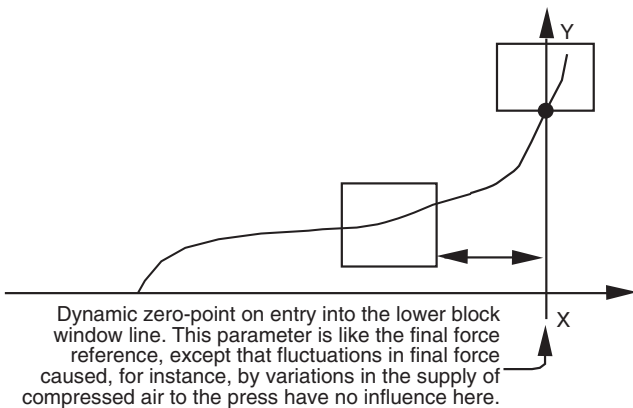

**Measurement Functions**

DIGIFORCE® provides various measurement functions for various applications:

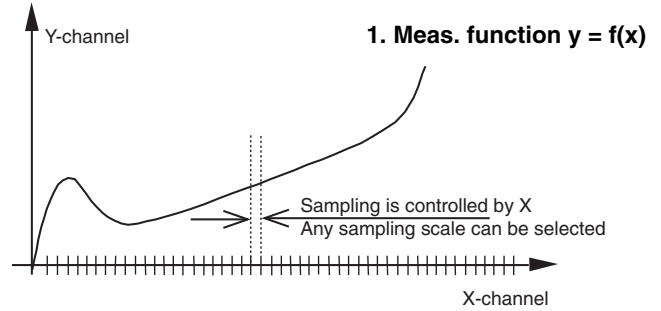

A measurement variable Y is recorded and evaluated as a function of measurement variable X. A variable X-scale determines the reading of the X-Y-value pairs. The advantage: Readings only occur for changes in the X-value. Unlike time-controlled readings, (see below) the storage unit for the measured value is not unnecessarily filled, for example, for the intermediate stop of a feed unit. However, this type of measurement is not suitable for extremely steep curves, in ranges where there is scarcely any change in the X-value. In such cases one of the following functions would be more suitable.

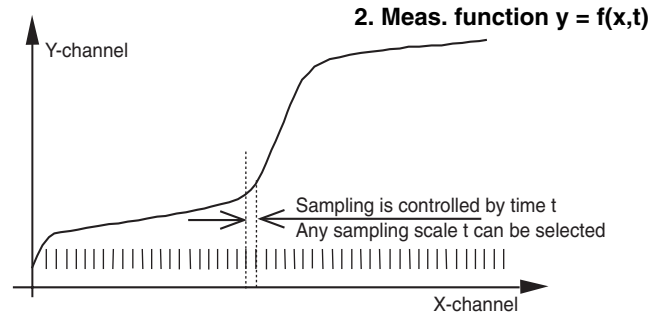

A measurement variable Y is recorded and evaluated as a function of a measurement variable X. A variable time scale t determines the reading of the X-Y-value pairs. The latter is thus carried out independent of changes in the measurement variable X. When steep curve slopes occur, like in the case of "Press on block", they are easy to record.

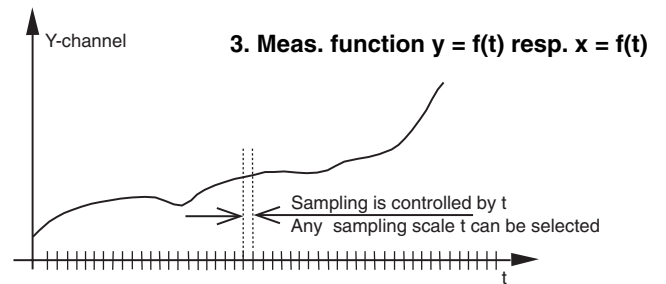

A measurement variable on channel Y or Y is recorded as a function of time t. The measurement variables of all sensors connectable to the Y-channel can be displayed as a function of time. This measurement function is only suited for processes reproducible in time, e.g. for always identical feeding speeds of a press. Advantage: the X-sensor can be dispensed with (e.g. displacement sensor).

**4. Classify X resp. Y**

Measurement variables on channels X or Y are subdivided into 5 classification groups. Each group is assigned a switching signal. This is how you can automatically sort, for example, springs according to spring rates. A statistic menu provides information on how many items occur in which class. Instantaneous min., max. or mean values can be classified. While instantaneous values are marked by the edge of an external switching signal, the min., max. or mean value detection is active in the high phase of this switching signal.

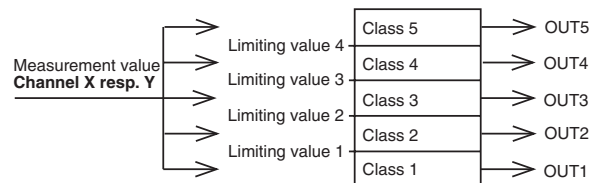

## Process Information

The operator can thumb through the following diagnostic pages without stopping the system and disturbing the process:

### 1. NIO percentage of the individual screens

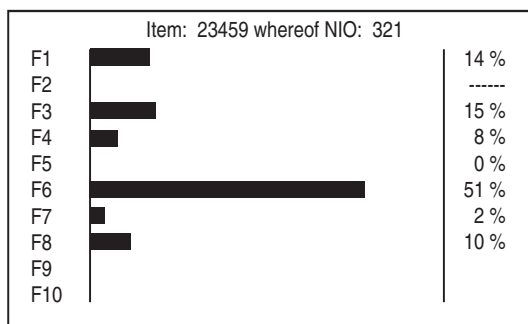

In the above example it is immediately clear that window 6 causes the most NIOs. Here the corresponding counter-measures must be initiated. Help in form of plain text can be deposited for each window and called-up when needed.

### 2. Help on an accumulation of NOK items

If a process threatens to go haywire due to frequent instances of NOK, the DIGIFORCE® does not leave you in the lurch.

For every evaluation window, a special help text can be stored in the form of a work instruction.

PROGRAM 1	PROGRAM NAME	STATUS
WINDOW1	ITEM 1578	NIO 8
WINDOW 1 CONTROLS THE BUFFING OF JOINED ELEMENTS A FREQUENT OCCURRENCE OF NOKS ENTAILS THE FOLLOWING CHECKS 1. CLEARANCE 0815 WITH GAUGE 4711 2. SINK DEPTH OF THE BEARING SEAT 3. BOLT PHASE 4. LUBRICANT 007 CALL FOREMEN SCHULZ IN AN EMERGENCY (PHONE +49-(0)7224-6450) BUT NOT AFTER 11 P.M. !!!		

### 3. Trend development of the window's entry and exit values

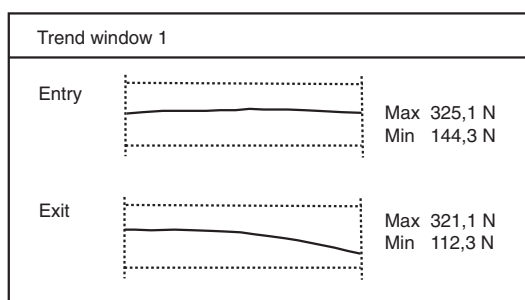

A trend display can be called-up for each window. This is produced by stringing together the window's entry or exit values of the last two thousand measurement curves. The dashed lines above or below the trend curves represent the respective window limits. The aim of this diagnostic page is early recognition of gradual drifting of curve sections.

### 4. Frequency distribution of the entry and exit values

The entry and exit values of all windows are collected and displayed graphically as a frequency distribution curve. The two marks on the X-axis represent the window limits.

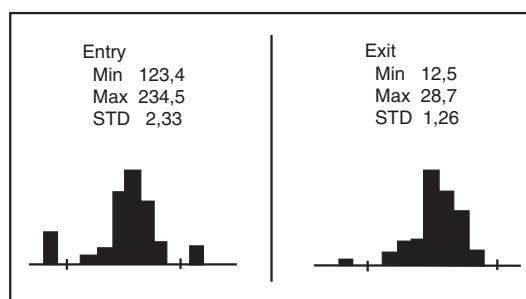

### 5. Graphic display of the measurement curve

The last respective measurement curve is displayed. The evaluation results for all involved windows are displayed. A reference curve can be overlaid for the current measurement curve simply by pressing a button (shown as a dashed line). An arrow indicates the damaged window page.

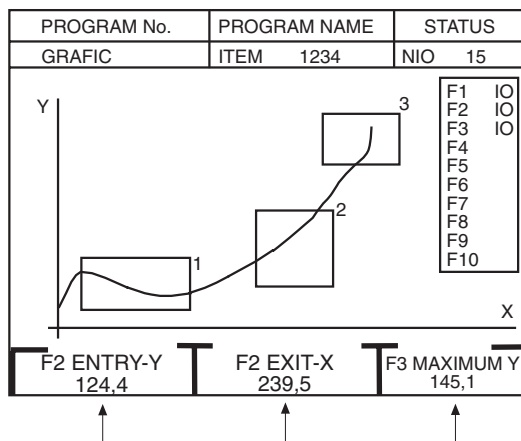

### 6. Displaying the min.-max.-values of all windows

PROGRAM No.	PROGRAM NAME	STATUS
NUMERIC 1	ITEM 1234	NIO 15
	MIN	MAX
	TYPE X Y X Y	
	[mm] [N] [mm] [N]	

F1	D	22.84	16.54	23.12	20.21	IO
F2	D	23.36	25.02	23.99	39.80	IO
F3	B	49.10	38.21	54.23	82.59	NIO
F4	A					
F5	A					
F6	A					
F7	A					
F8	A					
F9	A					
F10	A					

### 7. Display of up to 10 freely selectable values

Of a total of 88 statistical values available after every measurement, it is possible to select any 10 and represent them on the NUMERIC 4 info page. These 10 values can also be retrieved via the serial interface by means of a single command.

PROGRAM 1	PROGRAM NAME	STATUS
NUMERIC 4		
	Y-MAXIMUM	(X)
	Y-MAXIMUM	(Y)
	F 1-ENTRY	(Y)
	F 1-MINIMUM	(Y)
	F 2-ENTRY	(Y)
	F 3-ENTRY	(Y)
	F 3-EXIT	(X)
	F 3-MAXIMUM	(Y)
	F 8-ENTRY	(X)
	F 8-MAXIMUM	(Y)

### 8. Displaying the min.-max.-values of all curves

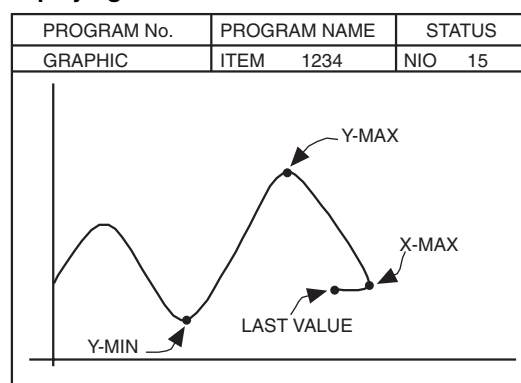

## Measurement Programs

For fast workpiece changes, DIGIFORCE® can store up to 32 measurement programs, which can be executed either by PLC or by hand.

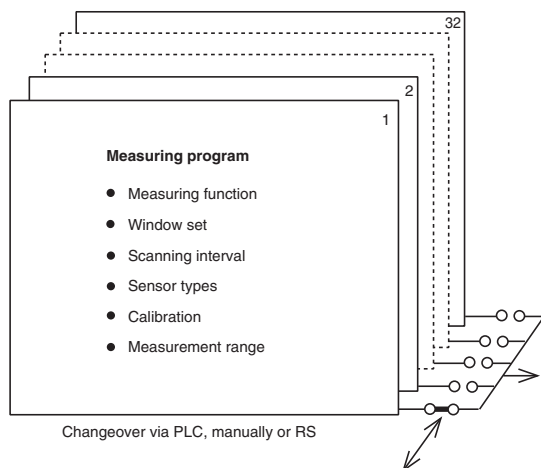

## Connectable sensors

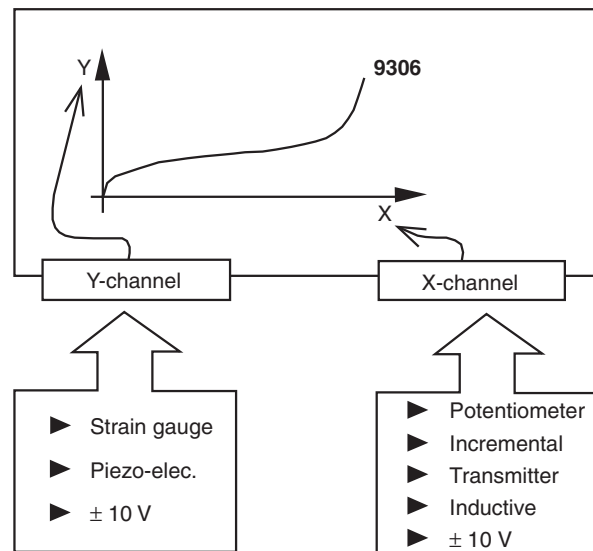

## Signals for Feed Control

For feed control, for example, of a press, DIGIFORCE® supplies two X-dependent (e.g. displacement dependent) real time signals. The switching thresholds for this can be set as desired. They can be related to the absolute (calibrated) or relative (trigger) zero point. Thus a press can be switched e.g. between "fast" and "slow" speeds.



## Adjusting the Measurement Channels

The adjustment of the sensor interface (signal type, gain, feed voltage etc.) is carried out using the menu. No adjustments need to be made on the hardware. There are no jumpers and no control knobs!

## Calibrating the Measurement Channels

- Three procedures:
1. Teach-in calibration
  2. According to sensor protocol
  3. Shunt calibration

A different calibration set can be assigned to each measurement program. When switching measurement programs you also automatically change the calibration.

## Sensor Control

Reference values can be taught-in and equipped with tolerance limits by means of a teach-in procedure. Triggered off by a control signal those limits can be steered for in defined intervals in order to verify them. If sensors are within tolerance limits DIGIFORCE® delivers a IO-ST signal to the control. Faulty measurements due to defective or drifting sensors are therefore mostly excluded.

## Access Protection

Because the keys for the key switches are frequently unavailable, we have solved this problem with passwords. This has the additional advantage that different users are only assigned certain access levels through the allocation of different passwords. A master USER generally has access to all settings. In the installation phases password queries are usually bothersome and for that reason can be disabled.

Example for different USER authorization:

Access authorization		
	USER1	USER2
Basic setting	<input type="checkbox"/>	<input type="checkbox"/>
Channel setting	<input type="checkbox"/>	<input type="checkbox"/>
Calibration	<input checked="" type="checkbox"/>	<input type="checkbox"/>
Meas. procedure	<input checked="" type="checkbox"/>	<input type="checkbox"/>
Evaluation limits	<input checked="" type="checkbox"/>	<input checked="" type="checkbox"/>
Statistics	<input checked="" type="checkbox"/>	<input type="checkbox"/>
Installation	<input checked="" type="checkbox"/>	<input checked="" type="checkbox"/>
Data output	<input checked="" type="checkbox"/>	<input checked="" type="checkbox"/>

## BUS link



The PROFIBUS option offers users an interface with a very high transmission rate. A processor dedicated specially to this interface and the use of dual ported RAMs provide the shortest possible access times even while measurements are in progress.

**Cyclic services:** PROFIBUS DP  
16 pre-defined modes

**Acyclic services:** PROFIBUS DPV1

The following functions are available:

1. Complete device control. This function replaces the standard PLC link via digital inputs/outputs.
2. Read out of measurement curves, statistical data and evaluation results.
3. Complete device parametrization.
4. Simultaneous use of the RS232/RS485 interfaces, for example, to connect a printer or DigiControl PC software.

- ▶ BUS link: 1 x DB9
- ▶ Galvanic isolation
- ▶ Baud rate: max. 12 MBaud

## Tools for Laboratory Application

The following functions are provided directly by the device.

### 1. Curve gauging

The up-to-date measurement curve shown on the display can be gauged by a cursor ruler. The Y value is indicated at the cursor position X.

Example: The force-displacement curve of a disc spring is recorded in the laboratory and displayed in the graphic display. The developer is interested in the force and the corresponding displacement in the knee of the curve. For this he or she positions the cursor ruler at this point and obtains a display of the values sought after.

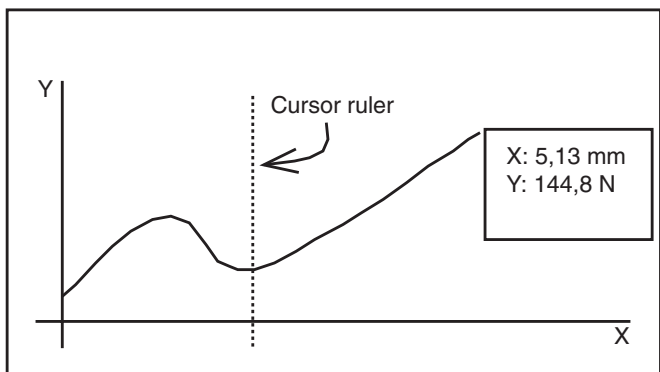

### 2. Determining the min.-max. value

From the coordinate range of a window of the "pass through" type the Ymin and Ymax values can be output via the graphic display.

Example: The developer of a cam switch is interested in the minimum and maximum torque of a prototype at an angle range of between 60° and 120°. He places a pass through window over this range and after each measurement obtains a display of the desired values.

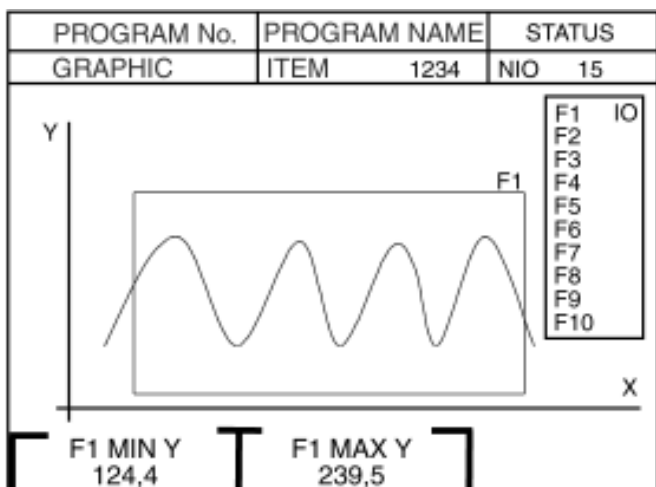

## PLC Programmable Control

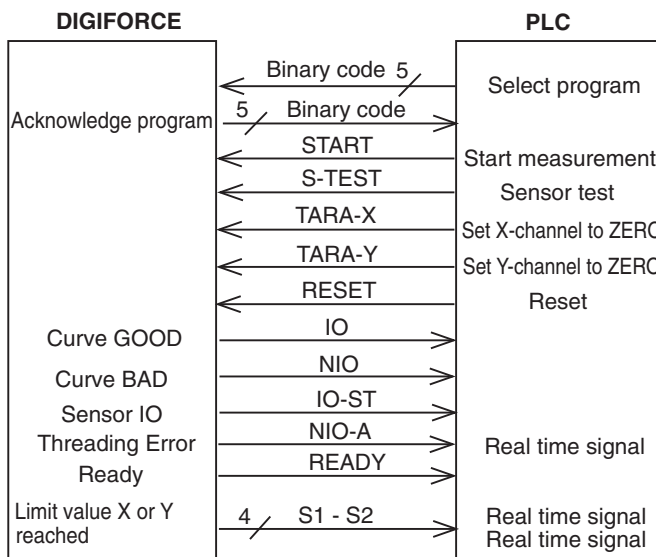

Only the most important signals are displayed!

All of the inputs and outputs are optically isolated.  
Two logic types are available (see order key):

1. Open E P current sourcing logic (primarily in Europe)

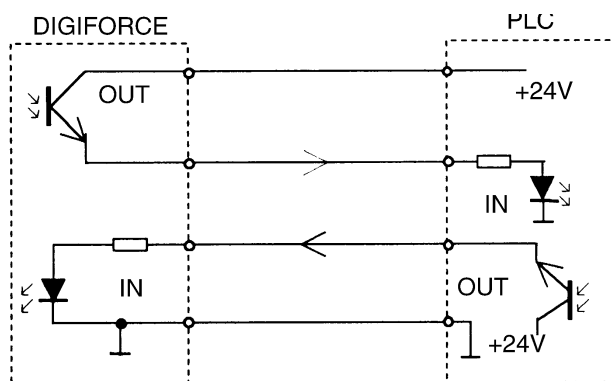

2. Open C N current sourcing logic (primarily USA)

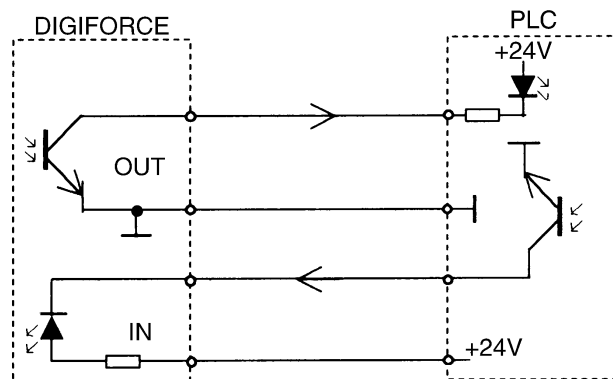

Plug connection: SUB-D type  
All inputs and output are optically decoupled.

## Documenting Measurement Results

Measurement results can be printed out by means of a printer connected directly or transferred to a computer. Thus the measurement curves or evaluation results can be appropriately archived with respect to parts. The user can decide via menu option whether only the IO, the NIO or all curves should be printed or transferred to a computer. For the documentation of the measurement results on a PC data storage medium you can obtain the software DIGIDRAW (order no. 9306-P002) optionally.

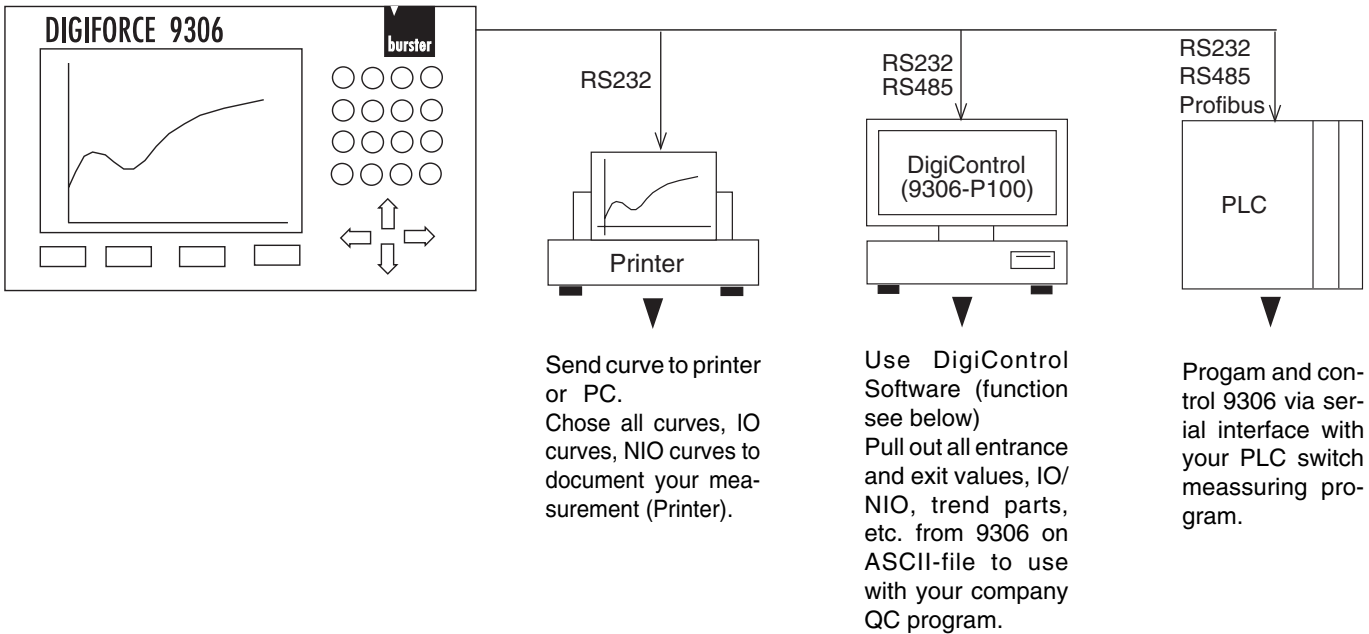

## DigiControl PC Software

The DIGIFORCE® operates independently without the need for any external aids whatsoever. However, the DigiControl Standard (basic version) and DigiControl Plus PC programs available as accessories offer a number of practical auxiliary tools:

- DigiControl basis version:** Backup function: All device settings are backed up on a data medium.
- Device setting: The DIGIFORCE® can be set entirely from a PC.
- DigiControl Plus:** Production mode: In addition to performing device settings and backups, it is possible to transmit, measure, store and archive curves.

Every measurement curve can be stored as an EXCEL file and processed further according to requirement:

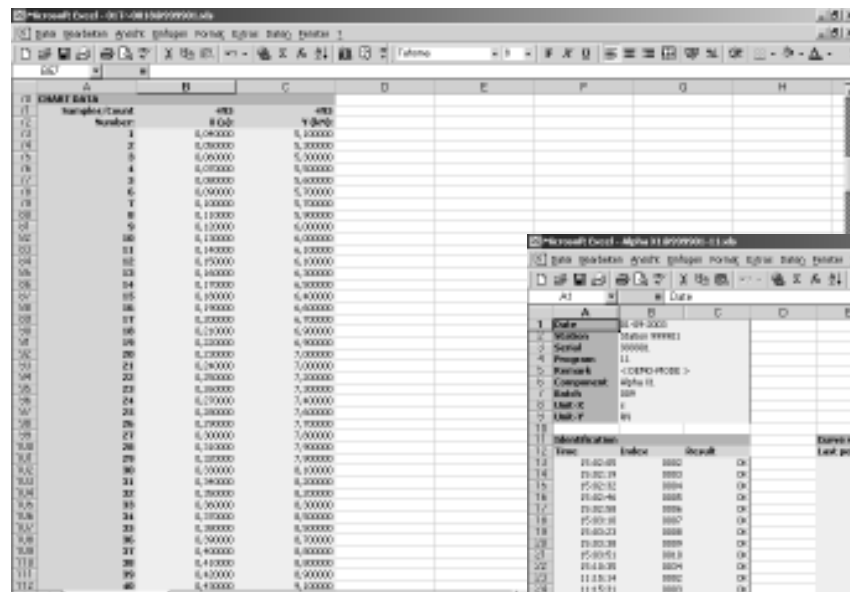

Significant values on a measurement curve, for instance, curve entry and exit values in evaluation windows can be stored in a statistics file (also EXCEL format). Each row of this file contains all the values pertaining to a pressing operation or workpiece determined by the DIGIFORCE®. Every column is assigned to a particular feature. For example, it is possible to monitor block dimension scattering for several thousand parts.

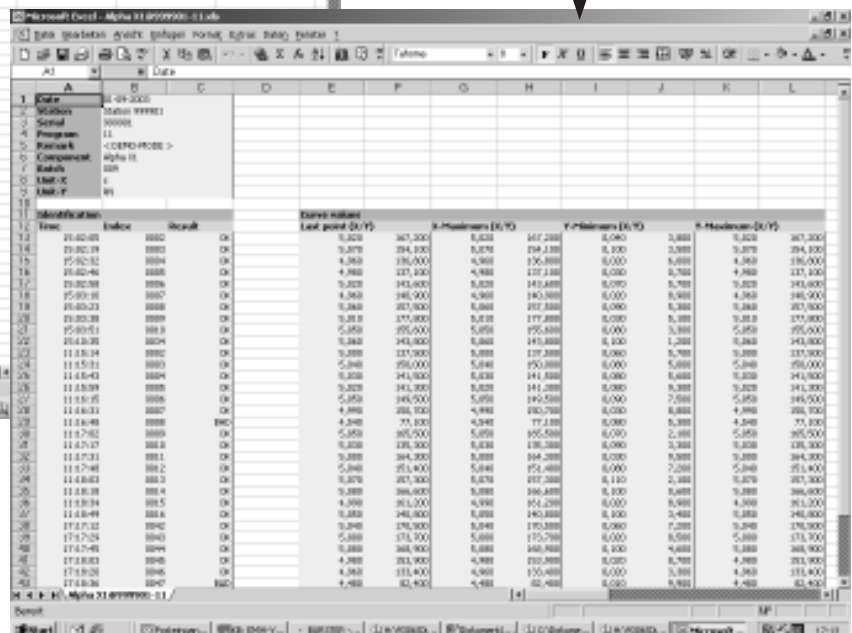



## Technical Data

### General data

Sampling rate:	10 000 value pairs/s
Digitalization:	12 bit (11 bit + sign)
Memory depth:	8000 value pairs for meas. curve
Evaluation time:	approx. 50 ms per window
Operating temperature range:	+ 5 ... $\pm 23$ ... + 50 °C
Storage temperature range:	0 ... + 60 °C
Mains connection:	230 VAC / 25 VA or 115 VAC / 25 VA

### Sensors for Y-channel

#### Strain-gauge

Parameters:	$\pm 0,2 \dots 25$ mV/V
Bridge resistor:	100 $\Omega$ ... 5 k $\Omega$
Feed voltage:	2.5 V or 5 V
Feed current:	100 mA
Feed type:	2 energy, 2 sensor lines
Max. frequency:	50 / 400 / 5000 Hz selectable via menu
Meas. deviation:	< 0.1 % typ.

#### Process signals

Signal range:	$\pm 5$ V, $\pm 10$ V
Meas. deviation:	< 0.1 %

#### Piezo-electric sensors

Meas. ranges:	$\pm 50$ pC ... $\pm 5000$ nC
Max. frequency:	50 / 400 / 5000 Hz selectable via menu
Meas. deviation:	< 1 %

### Sensors for X-channel

#### Potentiometer, DC/DC sensors, process signals

Input voltage ranges:	$\pm 5 / \pm 10$ V
Feed voltage:	5 / 10 V
Feed current:	approx. 100 mA max.
Max. frequency:	50 / 400 / 5000 Hz selectable via menu
Meas. deviation:	< 0.1 %

#### Incremental sensors

Sensors with and without reference marks are connectable, whose encoding consists of two pulse trains phase-shifted by 90°.

#### With sinusoidal current output

Signal:	7 ... 16 $\mu$ A <sub>PP</sub>
Feed voltage:	+ 5 V, 200 mA, -5 V, 120 mA
Max. frequency:	50 kHz
Counting depth:	16 bit

#### With TTL output

Signal:	5 V
Feed voltage:	+ 5 V, 200 mA, -5 V, 120 mA
Matching resistor:	open
Max. frequency:	400 kHz
Counting depth:	16 bit

#### ILVDT and differential reactor-displacement sensors (optional)

Output signal range:	$\pm 25 \dots 1000$ mV
Sensor feed voltage:	1.5 V <sub>rms</sub>
Frequency:	5 kHz
Current:	max. 50 mA
Resistance:	as of 50 $\Omega$
Max. frequency:	approx. 1 kHz
End value drift:	50 ppm/K
Meas. deviation:	< 0.1 %

## Process information

Via display: Up-to-date reference curve  
 NIO statistic - numerical and graphical  
 Normal distribution of window entry values  
 Trend display of each window  
 Normal distribution of window exit values  
 Recommendation for counter-measures

Via PLC port:	<b>IO</b>	all windows correctly passed
	<b>NIO</b>	minimum one window damaged
	<b>NIOA</b>	Error during threading, online signal
	<b>PF</b>	XX percent NIO exceeded or XX-NIO in sequence

## Real time signals to the system control

<b>SX1</b>	Threshold 1 on ch. X reached
<b>SX2</b>	Threshold 2 on ch. X reached
<b>SY1</b>	Threshold 1 on ch. Y reached
<b>SY2</b>	Threshold 2 on ch. Y reached

## Housing

### Table/Rack housing (see cover photo):

Protection class:	IP 40
Dimensions (L x H x W):	235 x 154 x 285 [mm]

### Wall housing (see inside brochure, 1st page):

Protection class:	IP 65
Dimensions (L x H x W):	265 x 150 (240) x 335 [mm]
Connection circuitry:	terminal block

## IP 65 housing

Side view

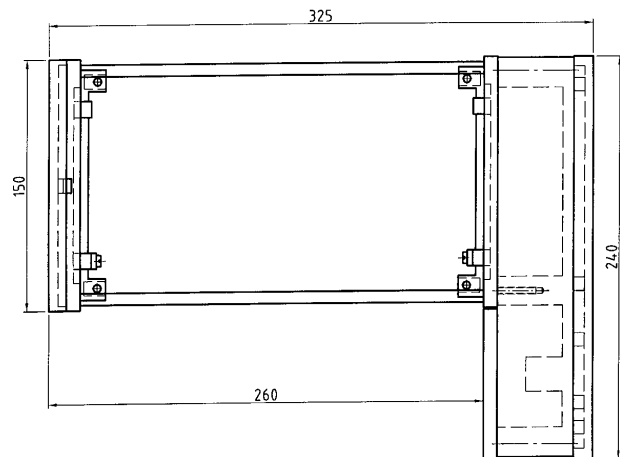

Top view

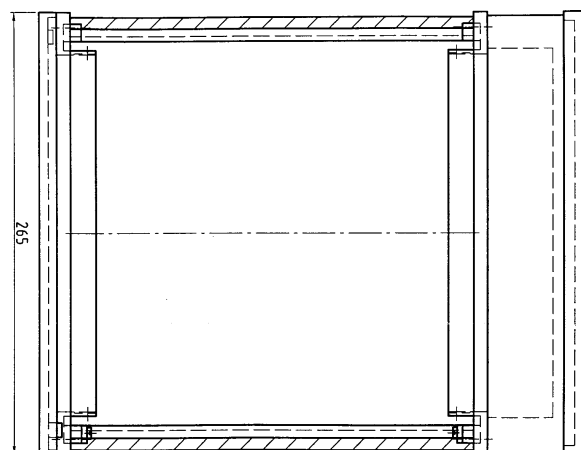

# Rear Panel of the DIGIFORCE® 9306 Table/Rack Version

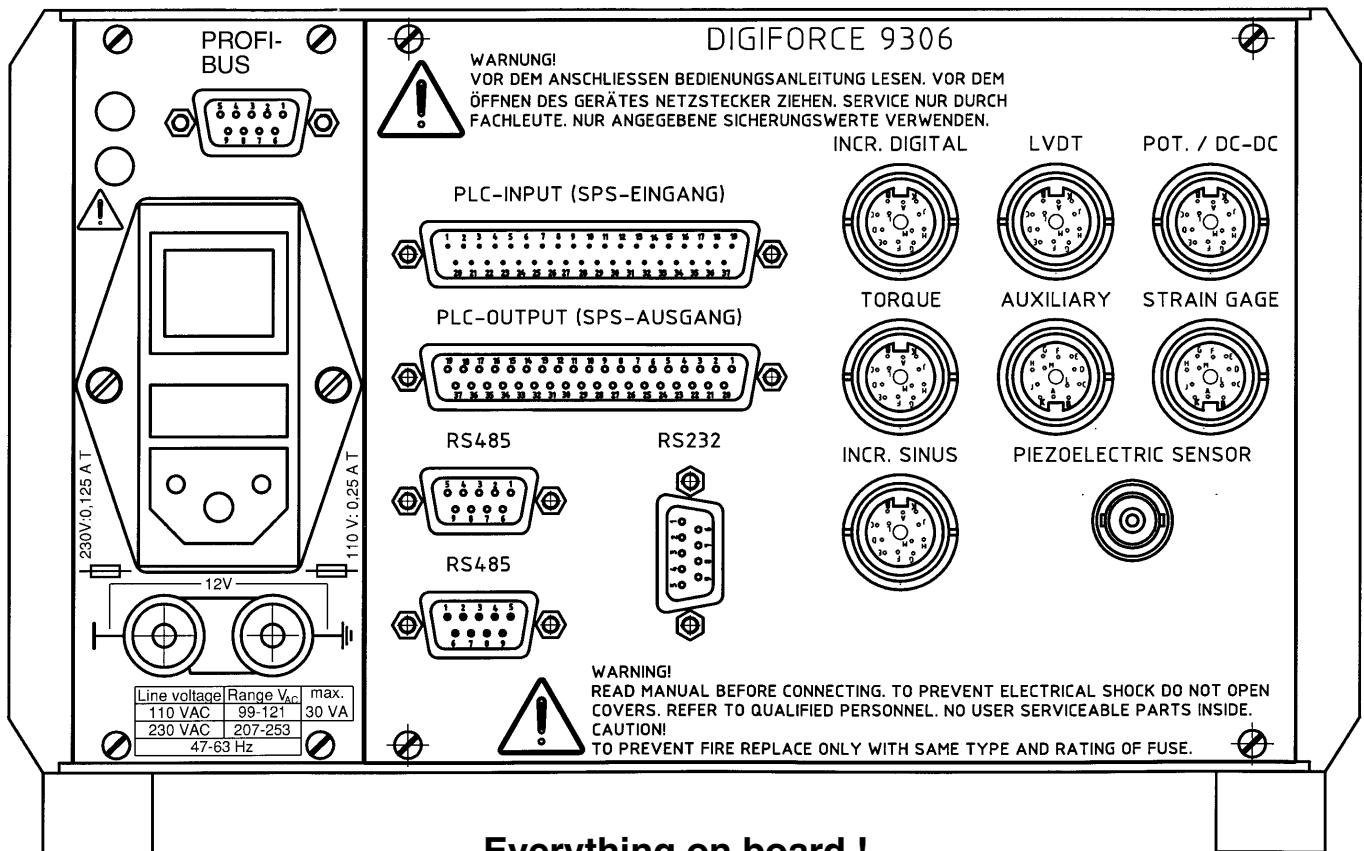

**Everything on board !**  
All conventional sensors can be connected directly.

## RS232/RS485

### Interface Parameter

The interface parameters can be set in the menu "basic interface settings".

Baudrate: 9600, 19200, 38400, 57600  
 Data bits: 8 (preset)  
 Stop bits: 1 (preset)  
 Parity: none, even, uneven  
 Block check: disabled or enabled no hardware handshake

### Interface Commands

The most important command groups are responsible for:

- general equipment setting
- establishing the measurement and evaluation procedure
- polling of the measurement results (curves, statistics)

### Printing measurement results

via the printer connectable directly to RS232

### Communication Protocol

The ANSI standard X3.28-1976 Subcategory 2.5, A4 is used as the communication protocol. This standard is used in systems in which several cascaded stations exist in a non-switching multipoint connection and all of the commands are transmitted by a control station. Only one master (transmitter) and one slave (receiver) are ever active on the bus. One station is the control station. The control station obtains master status and sends commands to a selected slave station or relinquishes its master status to one of the subordinate stations and then assumes slave status to receive data. A connection between two subordinate stations is not allowed. The control station monitors the connection the entire time.

## DIGIFORCE® Modifications

### DIGIFORCE® 9306-V5XX

With the DIGIFORCE® version 9306-V5XX up to 6 stations in succession can be monitored by using one sensor pair X/Y per station.

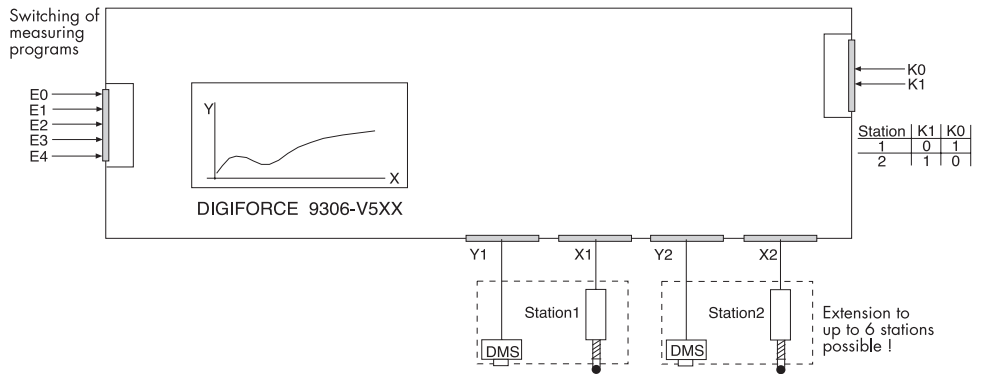

### DIGIFORCE® 9306-V000-DUO

The DUO version of the DIGIFORCE® permits autonomous monitoring of two stations with one sensor pair each (see the "switching point control" application on page 19).

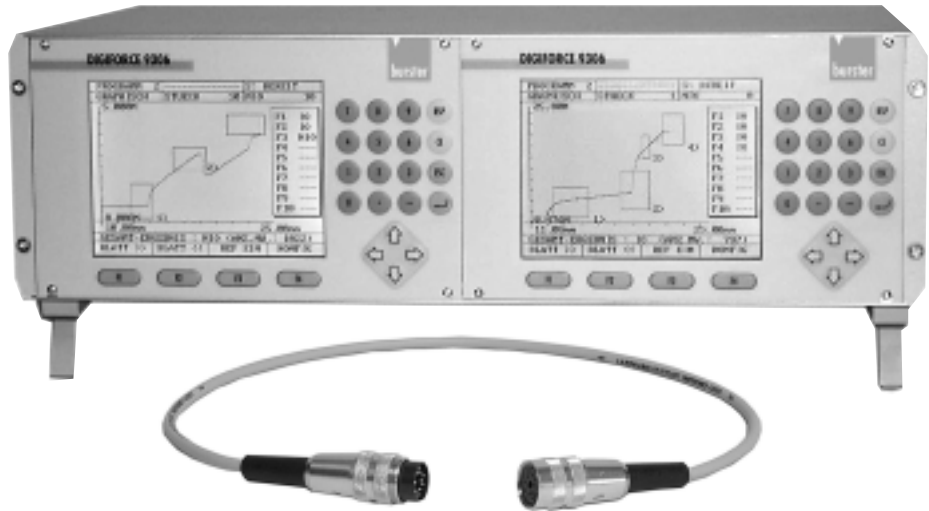

The bridging cable for potentiometers is used to connect through or cascade a potentiometric sensor to additional DIGIFORCE® equipment.

## DIGIFORCE® Accessories

### Testbox 9306-Box

To support system start-up the technician now has a useful tool at his disposal for PLC simulation.

LED's indicate the signal states on the I/O lines, switches simulate the PLC signals. Thus the entire handshake routine of a measurement program switchover can be performed. A changeover switch enables you to use the box on p- or n-switching logic elements.



## Service Offer

### 1. Application Support

Experienced engineers and technicians consult you in the run-up of your application, give you advice and hints for an optimal solution. More than 15 years experience in the field of process control mean aplenty of know how.

Contact us either by mail at **service@burster.de** or by phone at +49-7224-6450.

For North America your competent service partner is Physicom in Toronto, Canada. Contact them by email at **sales@a-tech.ca** or phone at +1-416-7547008.

### 2. Implementation and start-up support

Due to its well thought-out structuring the system DIGIFORCE® basically can be implemented and taken into operation by the customer himself. Anyway it may occur that upon more complex measuring tasks the support of a product professional is needed in order to integrate DIGIFORCE® into its engineering environment. In this case you may address to our export partners on location in your country. Our Representatives are well trained on our products and are looking forward to support you with the realization of your measurement application. Either you already have the contact through your purchase proceedings and business relationship with our export partner, or you can address us to manage a contact between you and our Representative.

Contact us on the web at **www.burster.com** for more information about the responsible export partner in your country.

### 3. After Sales Service

DIGIFORCE® is a quality product and is subject to very restrictive control procedures until its delivery to you. Nevertheless it is possible that at some point also such a high-sophisticated quality product can fail. In this case we provide you with our reliable hotline support, provided by in-house specialists working with our products in every possible way already since years and decades. Most of the time it is thus possible to eliminate an error which can also be caused by an unconsciously faulty operation. And in case that an error in the operation of the instrument cannot be removed by telephone support there is of course the possibility either to send-in the instrument to burster Germany – or to our export partners, who in many countries are able to effect the repair service on the location.

Contact us on the web at **www.burster.com** for more information about the responsible export partner in your country or send us an email to **service@burster.de** - or in very urgent cases you are free to give us a phone call on +49-7224-6450.

## Order Information

DIGIFORCE®	Model 9306 - V	<input type="checkbox"/>	<input type="checkbox"/>	<input type="checkbox"/>	<input type="checkbox"/>	-	<input type="checkbox"/>	<input type="checkbox"/>	<input type="checkbox"/>
<b>Standard</b>		<b>0</b>	<b>0</b>	<b>0</b>	<b>0</b>				
Desktop-rack housing IP 40 (standard)		0							
Wall-mounted housing IP 65 (option)		1							
Standard interface (DMS/Piezo/Poti/Incr./±10 V)			0						
Additional LVDT-interface (option)			1						
IO-channel-p-switching, power supply 230 VAC line					0				
IO-channel-n-switching, power supply 115 VAC line (no extra charge)					1				
IO-channel-p-switching, power supply 115 VAC (no extra charge)					2				
IO-channel-n-switching, power supply 230 VAC (no extra charge)					3				
RS232/485 (standard)						0			
Profibus DP (additional to RS232)						2			
2 x in one common housing IP40									DUO

## Accessories

- RS232 data cable PC to instrument 9900-K333
- PC-Software DigiControl 9306-P101
- PC-Software DigiControl (english version) including data cable 9306-P002
- PC-Software DigiControl plus 9306-P100
- Pin matrix for direct connection including appropriate data cable 9306-Z001
- Test box to indicate and simulate the I/O-signals of a PLC 9306-BOX
- Start box for the generation of external START signals 9306-Z003
- 19" mounting rack 9305-Z003
- Adapter cable for the connection of Heidenhain sensors 99141-619A-0270005
- Cable to cascade a potentiometric sensor (displacement channel) to an additional DIGIFORCE® 99141-540G-0090005

# Choosing the Right Sensors for DIGIFORCE®

DIGIFORCE® has a sensor interface to connect simultaneously up to two sensors at a time. The sensor principles are: strain gauge, piezo electric, LVDT, DC/DC, incremental, potentiometric or standard signals ( $\pm 5\text{ V}$ ,  $\pm 10\text{ V}$ ). Hereafter you will find a recommendation of suitable sensors from our sensor program. **Of course you can apply other brands that follow the mentioned sensor principles.**

## Load Cells (Miniature Design for Limited Space)

### Model 8438



- ▶ Clearance hole, if force has to be guided through sensor
- ▶ High protection class IP 65
- ▶ Very flat design
- ▶ Applicable for machine integration

Type	Measuring range	Dimensions [mm]													Thread G	Natural Frequency [kHz]
		$\phi$ D1	$\phi$ D2	$\phi$ D3	$\phi$ D4	$\phi$ D5	A	H	$\phi$ C	L	$\phi$ K	M	B	$\phi$ T		
8438 - 5500	0 ... 500 N	28.0	25.0	22.0	9.0	5.5 <sup>H8</sup>	7.0	8.0	2.2	8.0	1.9	2.5	-	-	-	3.7
8438 - 6001	0 ... 1 kN	38.0	29.0	25.0	13.5	7.0 <sup>H8</sup>	9.0	10.0	3.6	8.0	3.0	3.0	3.0	33.5	M 2.5x0.45	3.4
8438 - 6002	0 ... 2 kN	38.0	29.0	25.0	13.5	7.0 <sup>H8</sup>	9.0	10.0	3.6	8.0	3.0	3.0	3.0	33.5	M 2.5x0.45	5.5
8438 - 6005	0 ... 5 kN	38.0	29.0	25.0	13.5	7.0 <sup>H8</sup>	9.0	10.0	3.6	8.0	3.0	3.0	3.0	33.5	M 2.5x0.45	10.0
8438 - 6010	0 ... 10 kN	38.0	29.0	25.0	13.5	7.0 <sup>H8</sup>	9.0	10.0	3.6	8.0	3.0	3.0	3.0	33.5	M 2.5x0.45	15.0
8438 - 6020	0 ... 20 kN	49.0	41.0	35.0	23.0	15.0 <sup>H8</sup>	15.0	16.0	3.6	8.0	3.0	4.5	3.0	45.0	M 2.5x0.45	14.0
8438 - 6050	0 ... 50 kN	49.0	41.0	35.0	23.0	15.0 <sup>H8</sup>	15.0	16.0	3.6	8.0	3.0	4.5	3.0	45.0	M 2.5x0.45	24.0
8438 - 6100	0 ... 100 kN	78.0	60.0	54.0	42.0	28.0 <sup>H8</sup>	24.0	25.0	5.6	10.0	5.0	6.5	5.5	69.0	M 4.0x0.7	22.0
8438 - 6200	0 ... 200 kN	78.0	60.0	54.0	42.0	28.0 <sup>H8</sup>	24.0	25.0	5.6	10.0	5.0	6.5	5.5	69.0	M 4.0x0.7	37.0

Operating temperature range: 0 °C ... + 85 °C  
 Temperature compensated: + 15 °C ... + 70 °C  
 Temperature effect on zero:  $\leq \pm 0.03\%$  F.S./K  
 Temperature effect on span:  $\leq + 0.03\%$  Rdg./K  
 Non-linearity:  $\leq 1.0\%$  F.S.  
 Relative hysteresis:  $\leq 0.75\%$  F.S.  
 Non-repeatability with unchanged assembly position:  $\leq 0.25\%$  F.S.  
 Mounting:  
 Measuring range  $\geq 0 \dots 1000\text{ N}$  on bottom side there are three mounting holes, equally spaced on T diameter as shown.  
 This kind of mounting is allowed for compression load only.  
 Operating force max: 50 % over capacity  
 Dynamic load capacity:  
 recommended 50 % of capacity  
 max. 70 % of capacity  
 Material: stainless steel 1.4542  
 Electrical termination: cable, 2 m  
 Connector included with DIGIFORCE®; for mounting order no. 99004

### Size drawing

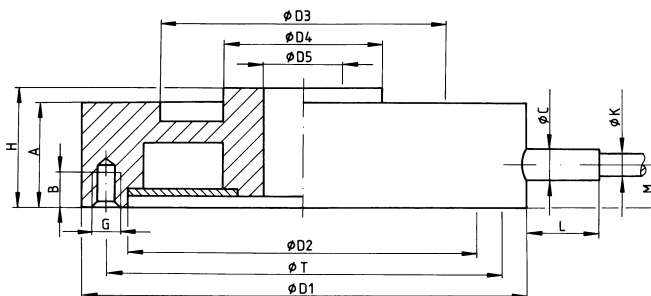

### Model 8402



- ▶ **Most compact in size**
- ▶ **Ideal to integrate into press tooling**
- ▶ **Rugged and wide range of force**

Order Code standard type	Measuring Range	Accuracy* [%F.S.]	Non-Repeatability [%F.S.]	Dimensions [mm]								
				ø D1	ø D2	F	A	H	G	ø C	ø K	M
8402-6001	0 ... 1 kN	≤ ± 0.75	≤ ± 0.4	6.4	12.7	3.05	14.9	9.6	0.25	1.9	2.8	1.6
8402-6002	0 ... 2 kN	≤ ± 0.5	≤ ± 0.25	6.8	12.7	3.05	14.9	9.6	0.25	1.9	2.8	1.6
8402-6005	0 ... 5 kN	≤ ± 0.5	≤ ± 0.25	7.7	12.7	3.05	14.9	9.6	0.25	1.9	2.8	1.6
8402-6010	0 ... 10 kN	≤ ± 0.5	≤ ± 0.25	10.0	12.7	3.05	14.9	9.6	0.25	1.9	2.8	1.6
8402-6020	0 ... 20 kN	≤ ± 0.5	≤ ± 0.25	14.0	15.9	6.0	16.5	16.0	0.25	1.9	2.8	3.1
8402-6050	0 ... 50 kN	≤ ± 0.5	≤ ± 0.25	19.7	22.4	6.0	19.7	16.0	0.25	1.9	2.8	3.1
8402-6100	0 ... 100 kN	≤ ± 0.5	≤ ± 0.25	26.5	44.0	15.0	35.0	38.0	0.5	3.0	7.0	7.5

\* The figures specified are the combined values for non-linearity, hysteresis and non-repeatability.

Temperature operating: -30 °C ... 100 °C  
 Temperature compensated: 15 °C ... 70 °C  
 Deflection: ≤ 50 µm  
 Overload safe: 50 % over capacity  
 Dynamic performance: recommended 70 % of capacity  
 Material: stainless steel 1.4542  
 Resonance frequency: > 20 kHz  
 Electrical termination: cable, 2 m  
 Connector included with DIGIFORCE®; for mounting **order no. 99004**

**Size drawing**

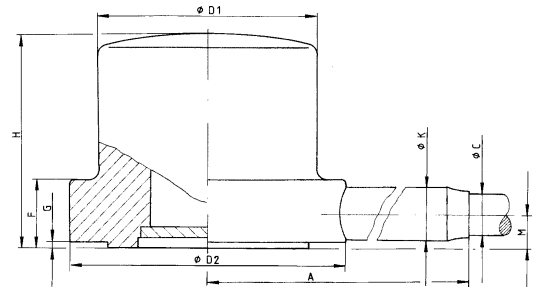

## Load Cells (Standard Design for Sufficient Space)

### Model 8524



- ▶ **Precise 0.25 % accuracy load cell**
- ▶ **Very rugged design**
- ▶ **Push or pull applications**

Order Code	Measuring Range	Dimensions [mm]									Thread T	Clearance Holes on G	Natural Frequency [kHz]	Mass [kg]
		ø D1	ø D2	ø D3	H	ø G	ø X	ø Y	W					
8524-5500	0 ... 0.5 kN	54.5	15	35.5	16	45	4.3	8	11.4	M 8 x 1.25	3	> 2	0.25	
8524-6001	0 ... 1 kN	54.5	15	35.5	16	45	4.3	8	11.4	M 8 x 1.25	3	> 3	0.25	
8524-6002	0 ... 2 kN	54.5	15	35.5	16	45	4.3	8	11.4	M 8 x 1.25	3	> 5	0.25	
8524-6005	0 ... 5 kN	54.5	15	35.5	16	45	4.3	8	11.4	M 8 x 1.25	6	> 8	0.25	
8524-6010	0 ... 10 kN	54.5	15	35.5	16	45	4.3	8	11.4	M 8 x 1.25	6	> 12	0.25	
8524-6020	0 ... 20 kN	79.0	22	58.0	25	68	4.5	8	20.4	M 12 x 1.5	8	> 4	0.65	
8524-6050	0 ... 50 kN	119.0	44	94.0	35	105	6.6	11	28.2	M 24 x 1.5	8	> 3	2	
8524-6100	0 ... 100 kN	155.0	60	109.0	50	129	13.5	20	36.5	M 36 x 3	8	> 3	5	
8524-6200	0 ... 200 kN	155.0	60	109.0	50	129	13.5	20	36.5	M 36 x 3	8	> 5	5	

Accuracy: combined value for non-linearity, hysteresis and repeatability < ± 0.25 % F.S.  
 Kind of measurement: Tension and compression (calibrated in compression direction)  
 Temperature operating: -30 °C ... 80 °C  
 Temperature compensated: 15 °C ... 70 °C  
 Deflection, full scale: approx. 80 µm  
 Overload safe: 50 % over capacity  
 Material: stainless steel 1.4542  
 Protection class: according to DIN 40050 ≤ 10 kN IP 52  
 ≥ 20 kN IP 64  
 Electrical termination: cable, 2 m  
 Connector included with DIGIFORCE®; for mounting **order no. 99004**

**Size drawing**

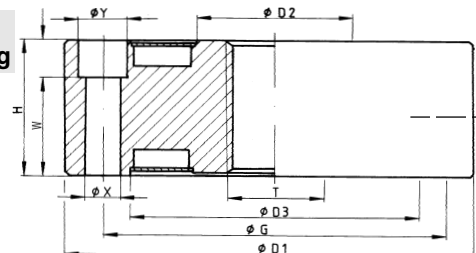

electrical termination: for details see in load cells data sheet

**Load button** type 8580-V... for compression force, hardened by induction HRC 55-60

**Pull plate** typ 8590-V... allows the tension or compression force to be directed at the center line

### Model 8526



- ▶ Compact and flat design
- ▶ High protection class IP 64
- ▶ Compression only

Order Code	Measuring Range	Dimensions [mm]								3 mounting holes G on $\phi T$ with metric thread	Dimensions [mm]							Mass [kg]	Natural Frequency [kHz]
		$\phi D1$	$\phi D2$	$\phi D3$	$\phi D4$	$\phi D5$	H1	H2	$\phi T$		N	$\phi A$	$\phi B$	$\phi C$	K	L	M		
8526 - 5100	0 ... 100 N	31.8	29.4	20.6	8.1	19.0	9.9	8.1	25.4	M 2.5	3	-	3	2	-	40	2.5	0.04	2
8526 - 5200	0 ... 200 N	31.8	29.4	20.6	8.1	19.0	9.9	8.1	25.4	M 2.5	3	-	3	2	-	40	2.5	0.04	3
8526 - 5500	0 ... 500 N	31.8	29.4	20.6	8.1	19.0	9.9	8.1	25.4	M 2.5	3	-	3	2	-	40	2.5	0.04	5
8526 - 6001	0 ... 1 kN	31.8	29.4	20.6	8.1	19.0	9.9	8.1	25.4	M 2.5	3	-	3	2	-	40	2.5	0.04	8
8526 - 6002	0 ... 2 kN	31.8	29.4	20.6	8.1	19.0	9.9	8.1	25.4	M 2.5	3	-	3	2	-	40	2.5	0.04	11
8526 - 6005	0 ... 5 kN	31.8	29.4	20.6	8.1	19.0	9.9	8.1	25.4	M 2.5	3	-	3	2	-	40	2.5	0.04	17
8526 - 6010	0 ... 10 kN	31.8	29.4	20.6	8.1	19.0	9.9	8.1	25.4	M 2.5	3	-	3	2	-	40	2.5	0.05	25
8526 - 6020	0 ... 20 kN	38.1	35.0	28.0	10.7	27.0	16.0	14.0	31.5	M 2.5	3	-	4.5	3	-	45	3	0.05	25
8526 - 6050	0 ... 50 kN	38.1	35.0	28.0	10.7	27.0	16.0	14.0	31.5	M 2.5	3	-	4.5	3	-	45	3	0.05	40
8526 - 6100	0 ... 100 kN	50.8	48.0	36.0	15.2	33.0	25.4	22.4	42.0	M 4.0	6	7	4.5	3	11	46	6	0.3	40
8526 - 6200	0 ... 200 kN	76.2	74.0	46.0	20.0	45.0	38.1	33.5	60.0	M 4.0	6	7	4.5	3	11	46	6	1.2	40

Accuracy: combined value for non-linearity, hysteresis and repeatability nominal 0.5 % F.S.  
 Temperature operating: - 20 °C ... + 100 °C  
 Temperature compensated: +15 °C ... + 70 °C  
 Deflection, full scale: 10  $\mu$ m ... 80  $\mu$ m  
 Overload safe: 50 % over capacity  
 Dynamic performance: recommended 50 % of capacity, permitted 70 % of capacity  
 Mounting: Bottom side with three 3 mm (M 2.5) or 6 mm (M 4) deep mounting holes on diameter T, sharing 120°, see table.  
 Material: High-grade stainless steel 1.4542  
 Electrical termination: cable, 2 m  
 Connector included with DIGIFORCE®; for mounting order no. 99004

#### Size drawing

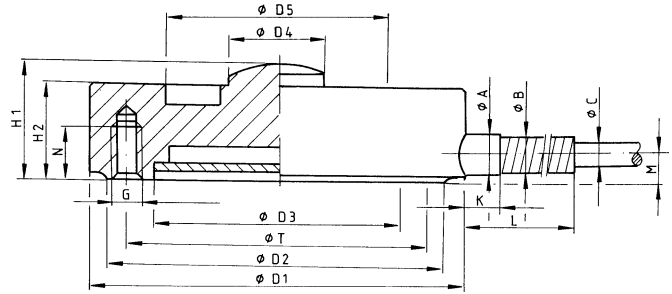

## Torque Transducers

### Model 86402



- ▶ Torque and angle measurement
- ▶ Compact size
- ▶ Ideal for quality testing applications in production

Order Code	Measuring Range	Drive	Dimensions [mm]												Max. axial load
			A	B	C	D	E	F	G	H	I	k	L	N	
86402-5012-V501	0 ... 12 Nm	1/4"	75	28	52	58	14	8.5	8	5	11	-	13	-	150 N
86402-5030-V501	0 ... 30 Nm	3/8"	101	38	58	59	19	21.5	14	5	12	35	25	17	550 N
86402-5063-V501	0 ... 63 Nm	3/8"	101	38	58	59	19	21.5	14	5	12	35	25	17	1000 N
86402-5160-V501	0 ... 160 Nm	1/2"	106	38	58	59	19	26	14	5	12	35	25	17	1800 N
86402-5500-V501	0 ... 500 Nm	3/4"	135	58	76	64	29	40	30	5	14	36	40	30	4000 N
86402-6001-V501	0 ... 1000 Nm	1"	177	73	90	73	36.5	57.5	45	5	14	45	50	40	6000 N

Non-linearity: <math>\pm 0.2\%</math> F.S.  
 Hysteresis: <math>\pm 0.1\%</math> F.S.  
 Operating temperature: 5 °C ... 50 °C  
 Overload safe: 50 % over capacity  
 Max. speed (short time): 3000 min<sup>-1</sup>  
 Angle measurement: 2 x 360 pulses, 90° displaced, TTL  
 Resolution: 1 °  
 Protection class: acc. to DIN 40050 IP 40  
 Cable to connect to DIGIFORCE® order no. 99132

#### Size drawing

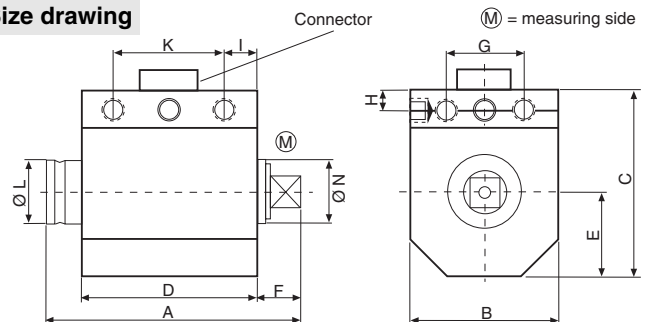

# Displacement Sensors

## Potentiometric

Model 8710, 8712

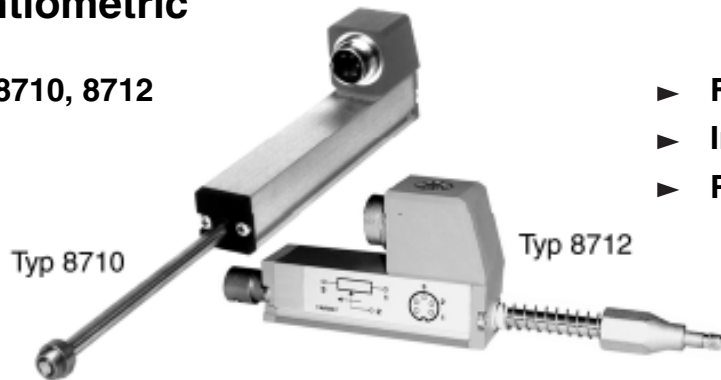

- ▶ Fit for most standard applications
- ▶ Inexpensive measurement solution
- ▶ Rugged, long lasting design

\*mechanical stroke

Order Code	Order Code	Measuring Range	Linearity [%F.S.]	Dimensions [mm] Model 8710			Dimensions [mm] Model 8712			
				A	B*	C	A	B	C	D
-	8712 - 10	0 ... 10 mm	± 0.3	-	-	-	48	15	32	108
8710 - 25	8712 - 25	0 ... 25 mm	± 0.2	63	30	107	63	30	32	138
8710 - 50	8712 - 50	0 ... 50 mm	± 0.1	88	55	157	88	55	40	196
8710 - 75	-	0 ... 75 mm	± 0.1	113	80	207	-	-	-	-
8710 - 100	8712 -100	0 ... 100 mm	± 0.1	138	105	257	138	105	40	296
8710 - 150	-	0 ... 150 mm	± 0.05	188	155	357	-	-	-	-

Operating temperature: -30 °C ... 100 °C  
 Infinite resolution: 0.01 mm  
 Life duration: >100 · 10<sup>6</sup> operations  
 Displacement force: Model 8710 ≤ 0.3 N  
 Model 8712 ≤ 4 N

Displacement speed: ≤ 10 m/s  
 Protection class: acc. to DIN 40050 IP 40  
 Cable to connect to DIGIFORCE® **order no. 99132**

Size drawing Model 8710

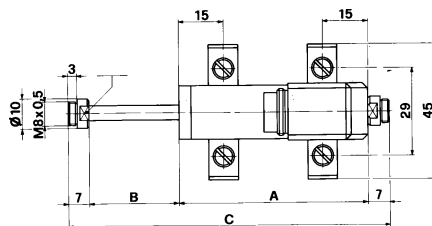

Size drawing Model 8712

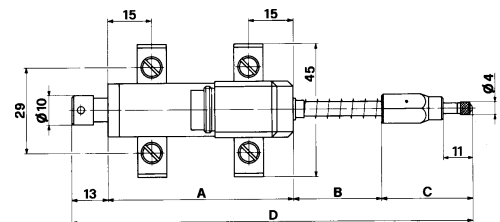

**LVDT** for application with

- ▶ High vibration level
  - ▶ When resolution and accuracy of potentiometric sensors are not sufficient
  - ▶ Use with DIGIFORCE® with optional LVDT interface, or connect to the standard model as DC/DC types
- Ask us for recommendation of sensors for your application

**Incremental** for application with

- ▶ Very high resolution
  - ▶ Short traveling path
  - ▶ Extremely high accuracy
  - ▶ Absolute travel path (reference point)
- Ask us for recommendation of sensors for your application

### Application note:

In order to attain high displacement resolutions, only the travel during actual pressing operation should be monitored. Measurements of displacement during the idle press stroke are usually not required. Path sensors solve this problem by performing mechanical coupling only just before contact is made with the part to be pressed.

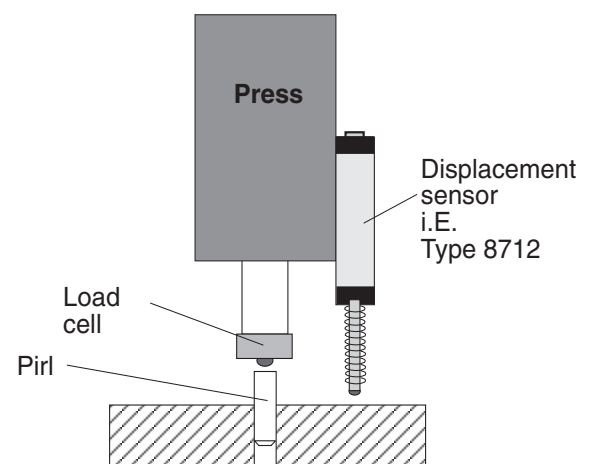

# Applications

## Pressing-in ball bearings

**Assignment:** When fully automatically producing gears, the critical process of pressing-in ball bearings must be monitored and documented.

**Solution:** DIGIFORCE® monitors the force-displacement characteristic.

Control criteria	Measuring window	Entrance	Exit
Threading (online) rapid switch-of	1	left	right
Transition adhesion-to sliding friction	2	any	bottom
Rise in friction	3	bottom	top
Blocking force	4	bottom	without

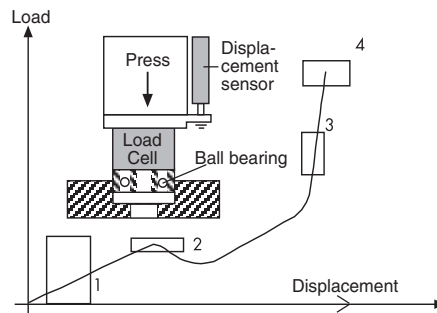

## Pressing-in pin and ball bearing

**Assignment:** A pin and a ball bearing must be pressed into a carrier plate.

**Solution:** The pressing-in operation is performed in two work stages. The pin is pressed-in first when the carrier plate is positioned under station 1. The PLC activates the appropriate sensors X1/Y1 for this and measuring program assigned to the pin. After the pressing-in operation the carrier plate is positioned under station 2. Now the ball bearing can be pressed-in. Prior to this the PLC switches over to the corresponding measuring program and the sensors for station 2.

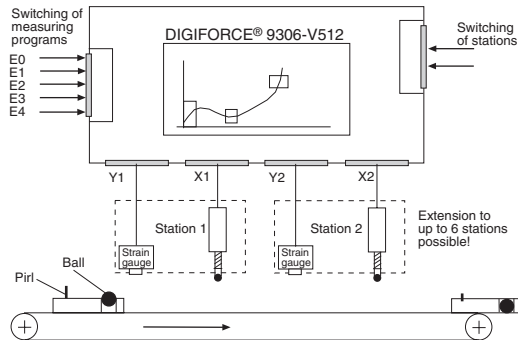

## Torque control of hinges

**Assignment:** Monitor the sluggishness of car door hinges over the entire turning range.

**Solution:** DIGIFORCE® detects the mean value of the torque within a selectable angle range using a torque sensor with integrated torque measurement. The controlled hinge is then subjected to an immediate classification into 5 classes. A switching signal is assigned to each class with which each device under test (hinge) can be sorted in terms of sluggishness.

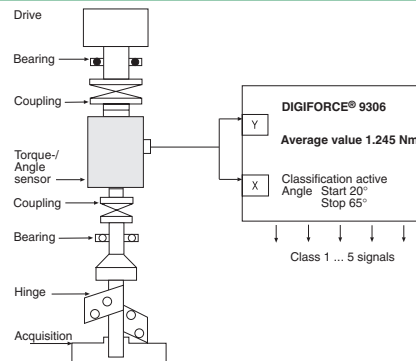

## Laboratory determination of the force-displacement characteristic for the preparation of mass production

**Assignment:** A complete 100% check of the force-displacement response of hammer clips must be performed for series production.

**Solution:** In order to get an idea of the dispersion potential expected before mass production starts, the data of each component from a pre-series is compiled using the DIGIFORCE® handpress and the DIGIDRAW PC software. This data is saved as an ASCII file so that EXCEL can then be used to determine mean values, standard deviation, min-max values etc. of the most varied inspection characteristics.

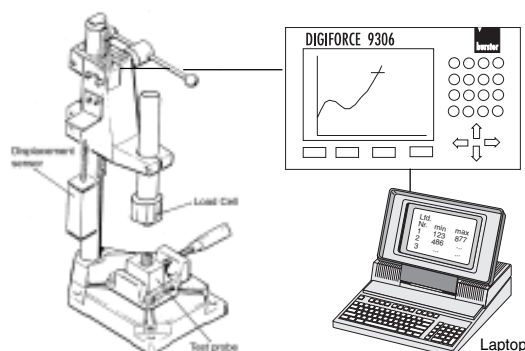

### Monitoring clicker element characteristics

**Assignment:** In harvesting threshers a signal indicates when it is time to change the suction filter. Here the vacuum level attained in the suction channel is a measure of how much dirt has accumulated in the filter. A diaphragm measures this and triggers a switch when a clicker element reaches sufficient deflection. The trigger point of this clicker element needs to be monitored.

**Solution:** A feeding device moves the clicker element across its working range. DIGIFORCE® monitors the force-displacement characteristic detected using corresponding sensor technology and generates corresponding evaluation signals as a function of this.

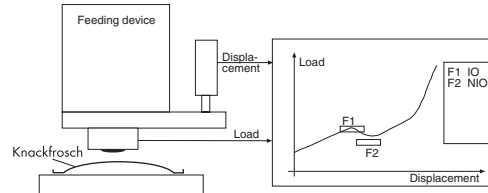

### Switching point control

**Assignment:** To check the force-displacement characteristic of an automotive switch and its switching point with respect to the contact travel.

**Solution:** A DIGIFORCE®-DUO is configured so that one pair of channel monitors the force-displacement characteristic  $F = f(S)$  and the second pair of channels monitors the contact travel for the switching point. The common displacement reference variable is obtained by connecting a bridging cable between the two displacement channels.

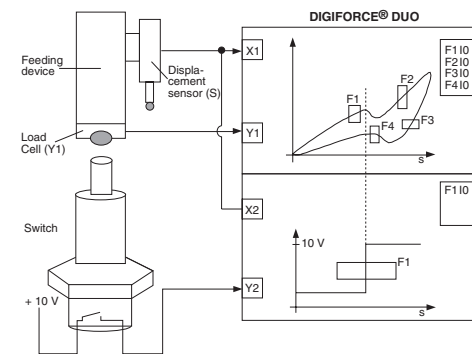

### Monitoring torque/angle of rotation of rotary switches

**Assignment:** Rotary switches in vehicles have to achieve pre-defined torque values when being turned and when locking into their individual positions.

**Solution:** DIGIFORCE® uses a torque/angle of rotation sensor to investigate the two measurement variables in their interdependency and records their corresponding maximum values.

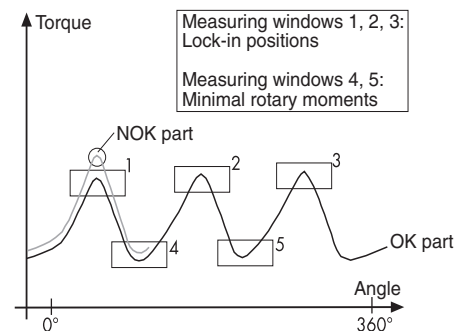

### Monitoring force-displacement of shock absorbers

**Assignment:** At the last station of an automatic production line for shock absorbers it is necessary to monitor their force-displacement characteristics.

**Assignment:** A rotary drive is used to contact and re-extend the shock absorber. DIGIFORCE® detects, records and evaluates this force-displacement measurement curve. The DIGIFORCE® then provides an ok or not-o.k. signal as a function of this curve's characteristic.

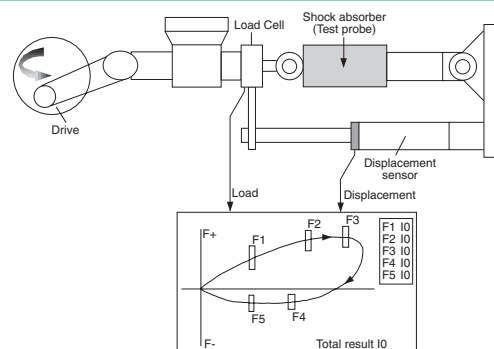

# Star date 9306... **DIGIFORCE**

is now to go where no man has gone before:  
the infinite realm of zero-error space



# Everything from one source



**DIGIFORCE®**  
**Type 9306**

With the right sensors  
for your application  
from burster

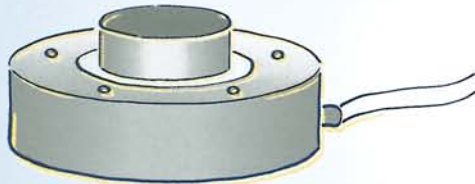

**Force (strain gauge)**

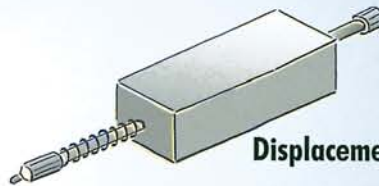

**Displacement (potentiometers)**

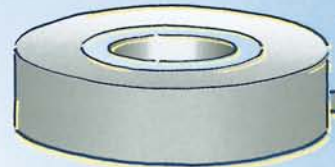

**Force (piezo-electric)**

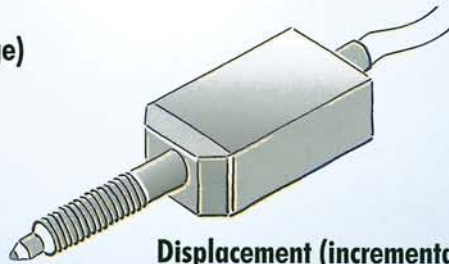

**Displacement (incremental)**

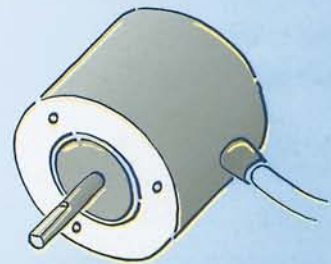

**Angular (incremental)**

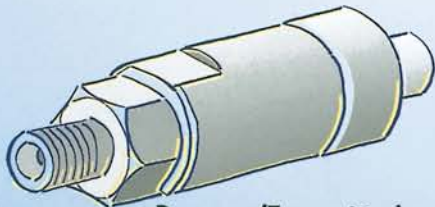

**Pressure (Transmitter)**

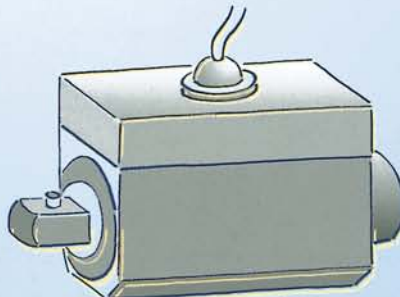

**Torque (strain gauge)**



**Displacement (LVDT)**

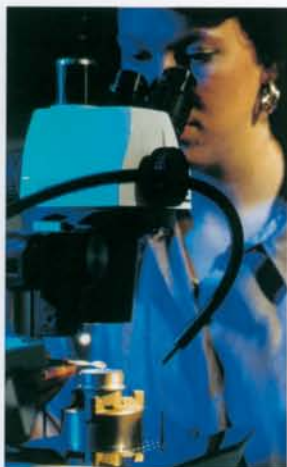

For almost 40 years the name burster has stood for application-oriented development and implementation of innovative solutions in the areas of sensor technology and sensor signal processing. Thanks to our dynamic team of engineers burster can now offer its customers a wide range of sophisticated measuring and testing solutions for such areas as quality assurance, automation, production and process flow optimization.



In addition to standard applications burster also develops customized concepts for its customers. And for all these applications we guarantee the optimum integration of the most diverse components.

Our own state-of-the-art manufacturing facilities at our headquarters in Gernsbach near Baden-Baden ensures consistently high-quality products.

## More Information



Your direct contact for more detailed information on **DIGIFORCE®**

## TELEFAX

Or just send us a fax with brief information on your particular application. We are more than happy to analyze your requirements and provide you with a customized solution.

### Your application

### Your address

Company

Name

Department

Street

Zip code/City

Telephone

Telefax

# DIGIFORCE® 9310

burster



## Press-Fit Control

# Press-Fit Control for More Safety

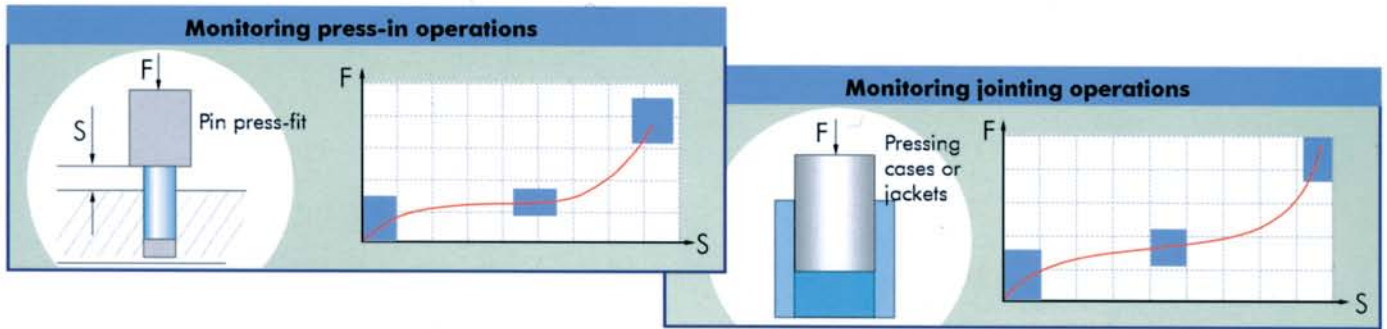

- ✓ Low price makes press-fit control available for everyone
- ✓ Small in dimension with 111 x 111 x 185 mm and easy installable
- ✓ More effectiveness with less claims
- ✓ Higher productivity possible with fast data recording and short reaction time
- ✓ Best possible recognition of faulty parts with the flexible and universal evaluation method
- ✓ Fast change of produced item's data via PLC and by hand with up to 8 different measurement programs
- ✓ Protection of the tools by real-time control with reaction times of the switching signals < 10 ms



## Application Sample „Hand Press“

Especially at simple hand presses where a 100 % control of the press-fit process is required, the DIGIFORCE® 9310 will pay off after a short time.

DIGIFORCE® 9310 keeps you updated and provides you with the important measurement results as a measurement curve or text – and if you prefer a globally understandable indication, you can set the DIGIFORCE® smiley to smile at the user when the press-fit process passed without objections.

With a wide selection of sensors we offer you the best and complete solution for almost all applications from one competent supplier.

**Don't hesitate to contact us –  
We are happy to be of assistance:**

**Mr. Stefan Körner**  
**burster gmbh & co kg**  
**Talstr. 1-5, Gernsbach 76593**  
**Tel: +49-7224-645-51 Fax: +49-7224-645-88**  
**www.burster.com**  
**stefan.koerner@burster.com**

